



df
1 A gG 421001
690 V~
I_n=80 kA 690 V~
I_n=120 kA 500 V~

df
22 X 58
63 A gG 422063
690 V~
I_n=80 kA 690 V~
I_n=120 kA 500 V~
IEC/EN 60269 CE

df
10 X 38
25 A gG 421025
500 V~
I_n=120 kA

df PMX
10x38
32A 690V~
485108

fuses & fuse holders

CYLINDRICAL



CYLINDRICAL

FUSES

PAGE **02** | gg CYLINDRICAL FUSES
PAGE **04** | gM CYLINDRICAL FUSES

FUSE HOLDERS

PAGE **06** | PMX MODULAR FUSE HOLDERS
PAGE **09** | PMC COMPACT FUSE HOLDERS FOR CC CLASS FUSE-LINKS
PAGE **09** | PMX-CC FUSE HOLDERS
PAGE **10** | PMF MODULAR FUSE BASES
PAGE **11** | BAC OPEN CONNECTION FUSE HOLDERS
PAGE **11** | PMB PLUG CONNECTION FOR Ø10 FUSE-LINKS
PAGE **11** | CLIP CONTACT FOR Ø10 FUSE-LINKS

CYLINDRICAL FUSES

gG CYLINDRICAL FUSES

Cylindrical fuse links gG class for use as general protection against overloads and short circuits, intended as protection of cables, power lines and equipment. Made of ceramic tube with high withstand to internal pressure and thermal shock, that allow a high breaking capacity in a reduced physical space. The melting elements are specially designed in order to avoid aging and thus maintain unalterable the electrical characteristics. Contact caps are made of silver plated copper. Versions available with fusing indicator or with striker for use in fuse holders with microswitch.

8x32

I _n (A)	REFERENCE		U (V)	BREAKING CAPACITY (kA)	REFERENCE WITH STRIKER	U (V)	BREAKING CAPACITY (kA)	PACKING Uni./BOX
	WITHOUT INDICATOR	WITH INDICATOR						
0,5	420500	-	400	20	-	-	-	10/100
1	420501	-	400	20	-	-	-	10/100
2	420502	420602	400	20	-	-	-	10/100
4	420504	420604	400	20	-	-	-	10/100
6	420506	420606	400	20	-	-	-	10/100
8	420508	420608	400	20	-	-	-	10/100
10	420510	420610	400	20	-	-	-	10/100
12	420512	420612	400	20	-	-	-	10/100
16	420516	420616	400	20	-	-	-	10/100
20	420720	420820	400	20	-	-	-	10/100



420500

10x38

0,5	420000	-	500	120	-	-	-	10/100
1	420001	-	500	120	-	-	-	10/100
2	420002	420102	500	120	-	-	-	10/100
4	420004	420104	500	120	-	-	-	10/100
6	420006	420106	500	120	-	-	-	10/100
8	420008	420108	500	120	-	-	-	10/100
10	420010	420110	500	120	-	-	-	10/100
12	420012	420112	500	120	-	-	-	10/100
16	420016	420116	500	120	-	-	-	10/100
20	420020	420120	500	120	-	-	-	10/100
25	420025	420125	500	120	-	-	-	10/100
32	420032	420132	400	120	-	-	-	10/100



420025

14x51

1	421001	-	690	80	-	-	-	10/50
2	421002	421102	690	80	421202	500	120	10/50
4	421004	421104	690	80	421204	500	120	10/50
6	421006	421106	690	80	421206	500	120	10/50
8	421008	421108	690	80	421208	500	120	10/50
10	421010	421110	690	80	421210	500	120	10/50
12	421012	421112	690	80	421212	500	120	10/50
16	421016	421116	690	80	421216	500	120	10/50
20	421020	421120	690	80	421220	500	120	10/50
25	421025	421125	690	80	421225	500	120	10/50
32	421032	421132	500	120	421232	500	120	10/50
40	421040	421140	500	120	421240	500	120	10/50
50	421050	421150	400	120	421250	400	120	10/50



CYLINDRICAL FUSES

gG CYLINDRICAL FUSES

	I _n (A)	REFERENCE		U (V)	BREAKING CAPACITY (kA)	REFERENCE WITH STRIKER	U (V)	BREAKING CAPACITY (kA)	PACKING Uni./BOX
		WITHOUT INDICATOR	WITH INDICATOR						
22x58	2	422002	422102	690	80	–	–	–	10/5
	4	422004	422104	690	80	422204	690	80	10/5
	6	422006	422106	690	80	422206	690	80	10/5
	8	422008	422108	690	80	422208	690	80	10/5
	10	422010	422110	690	80	422210	690	80	10/5
	12	422012	422112	690	80	422212	690	80	10/5
	16	422016	422116	690	80	422216	690	80	10/5
	20	422020	422120	690	80	422220	690	80	10/5
	25	422025	422125	690	80	422225	690	80	10/5
	32	422032	422132	690	80	422232	690	80	10/5
	40	422040	422140	690	80	422240	690	80	10/5
	50	422050	422150	690	80	422250	690	80	10/5
	63	422063	422163	690	80	422263	690	80	10/5
	80	422080	422180	500	120	422280	500	120	10/5
	100	422000	422100	500	120	422200	500	120	10/5
	125*	422015	422115	400	120	422215	400	120	10/5

* OVERRATING FUSES



gG aM NEUTRAL LINKS

SIZE	REFERENCE	PACKING Uni./BOX
8x32	430000	10/100
10x38	431000	10/100
14x51	432000	10/50
22x58	433000	10/50



431000

TECHNICAL gG CYLINDRICAL FUSES DIMENSIONS

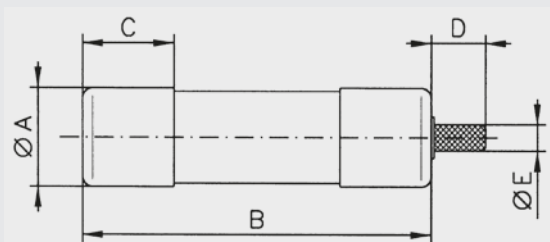

SIZE	A	B	C	D	E
8,5x31,5	8,5	31,5	6,3	–	–
10,3x38	10,3	38	8,5	–	–
14,3x51	14,3	51	11,5	8	4
22,2x58	22,2	58	15,5	8	4

CYLINDRICAL FUSES

aM CYLINDRICAL FUSES

Cylindrical fuse links aM class are intended for short circuit protection in motors, transformer and other load with high inrush currents. Excellent protection of switchgear (contactor, thermal switch) due to the good current limiting capability and low I^2t values. These fuse links must be associated to an overload device protection as a thermal switch. Made of ceramic tube with high withstand to internal pressure and thermal shock, that allow a high breaking capacity in a reduced physical space. The melting elements are silver plated in order to avoid the aging and thus keep unalterable the electric characteristics. Contacts caps are made of silver plated copper. Available versions with fusing indicator or with striker for use in fuse holders with microswitch.

	I_n (A)	REFERENCE		U (V)	BREAKING CAPACITY (kA)	REFERENCE WITH STRIKER	U (V)	BREAKING CAPACITY (kA)	PACKING Uni./BOX
		WITHOUT INDICATOR	WITH INDICATOR						
8x32	1	411101	411201	400	20	-	-	-	10/100
	2	411102	411202	400	20	-	-	-	10/100
	4	411104	411204	400	20	-	-	-	10/100
	6	411106	411206	400	20	-	-	-	10/100
	8	411108	-	400	20	-	-	-	10/100
	10	411110	411210	400	20	-	-	-	10/100



411106

10x38	0,16	440031	-	500	120	-	-	-	10/100
	0,25	440033	-	500	120	-	-	-	10/100
	0,5	440000	-	500	120	-	-	-	10/100
	1	440001	440101	500	120	-	-	-	10/100
	2	440002	440102	500	120	-	-	-	10/100
	4	440004	440104	500	120	-	-	-	10/100
	6	440006	440106	500	120	-	-	-	10/100
	8	440008	440108	500	120	-	-	-	10/100
	10	440010	440110	500	120	-	-	-	10/100
	12	440012	440112	500	120	-	-	-	10/100
	16	440016	440116	500	120	-	-	-	10/100
	20	440020	440120	400	120	-	-	-	10/100
	25	440025	440125	400	120	-	-	-	10/100



440006

14x51	0,25	441031	-	690	80	-	-	-	10/50
	0,5	441000	-	690	80	-	-	-	10/50
	1	441001	441101	690	80	441201	500	120	10/50
	2	441002	441102	690	80	441202	500	120	10/50
	4	441004	441104	690	80	441204	500	120	10/50
	6	441006	441106	690	80	441206	500	120	10/50
	8	441008	441108	690	80	441208	500	120	10/50
	10	441010	441110	690	80	441210	500	120	10/50
	12	441012	441112	690	80	441212	500	120	10/50
	16	441016	441116	690	80	441216	500	120	10/50
	20	441020	441120	690	80	441220	500	120	10/50
	25	441025	441125	690	80	441225	500	120	10/50
	32	441032	441132	500	120	441232	500	120	10/50
	40	441040	441140	500	120	441240	500	120	10/50
	45	441045	441145	500	120	441245	500	120	10/50
50	441050	441150	400	120	441250	400	120	10/50	



STANDARDS IEC 60269-1 IEC 60269-2 EN 60269-1 EN 60269-2	APPROVALS Cd-Pb FREE RoHS compliant REACH SVHC FREE	TECHNICAL I-t AND CUT-OFF CHARACTERISTICS PAGE 14	TECHNICAL I²t CHARACTERISTICS AND POWER DISSIPATION PAGE 15	COMPATIBLE PMX MODULAR FUSE HOLDERS PAGE 08	COMPATIBLE PMC & PMX-CC FUSE HOLDERS PAGE 09	COMPATIBLE PMF MODULAR FUSE HOLDERS PAGE 10	COMPATIBLE BAC OPEN FUSE HOLDERS PAGE 11	COMPATIBLE PMB SOCKET FUSE HOLDERS PAGE 11
--	---	--	--	--	---	--	---	---

CYLINDRICAL FUSES

aM CYLINDRICAL FUSES

	I _n (A)	REFERENCE		U (V)	BREAKING CAPACITY (kA)	REFERENCE WITH STRIKER	U (V)	BREAKING CAPACITY (kA)	PACKING Uni./BOX
		WITHOUT INDICATOR	WITH INDICATOR						
22x58	2	442002	442102	690	80	442202	690	80	10/50
	4	442004	442104	690	80	442204	690	80	10/50
	6	442006	442106	690	80	442206	690	80	10/50
	8	442008	442108	690	80	442208	690	80	10/50
	10	442010	442110	690	80	442210	690	80	10/50
	12	442012	442112	690	80	442212	690	80	10/50
	16	442016	442116	690	80	442216	690	80	10/50
	20	442020	442120	690	80	442220	690	80	10/50
	25	442025	442125	690	80	442225	690	80	10/50
	32	442032	442132	690	80	442232	690	80	10/50
	40	442040	442140	690	80	442240	690	80	10/50
	50	442050	442150	690	80	442250	690	80	10/50
	63	442063	442163	690	80	442263	690	80	10/50
	80	442080	442180	500	120	442280	500	120	10/50
	100	442000	442100	500	120	442200	500	120	10/50
	125*	442015	442115	400	120	442215	400	120	10/50

* OVERRATING FUSES



gG aM NEUTRAL LINKS

SIZE	REFERENCE	PACKING Uni./BOX
8x31	430000	10/100
10x38	431000	10/100
14x51	432000	10/50
22x58	433000	10/50



431000

TECHNICAL aM CYLINDRICAL FUSES DIMENSIONS

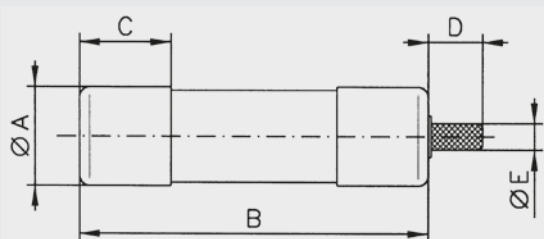

SIZE	A	B	C	D	E
8,5x31,5	8,5	31,5	6,3	-	-
10,3x38	10,3	38	8,5	-	-
14,3x51	14,3	51	11,5	8	4
22,2x58	22,2	58	15,5	8	4

CYLINDRICAL FUSE HOLDERS

PMX MODULAR FUSE HOLDERS NEW

- Available in a extended range of different versions with fuse indicator, with microswitch, 690V, 24 V DC, Microswitch FUSING+PRE-BREAKING+FUSE LINK DETECTION.
- Accessory available to lock the fuse holder by a padlock.
- IP20 Security accessory in terminal zones. For wires of section $\leq 10 \text{ mm}^2$.
- All the versions with label holder for a good circuit identification.
- Compact design.
- Accessories for multiple poles assembly for fuse holders and microswitch.
- Ventilation zones optimized for a better heat dissipation.
- 2 position DIN Rail fixation.
- Made of a polymer high performance with a fusion temperature more than 300 °C. This provides a safety margin against a possible overheating of the fuse, and when it exceeds the rated power acceptance of the fuse holder.
- The PMX fuse holder can be fixed/unfixed on DIN rail with the same screwing tools that the installer uses for cable terminal fixing, regardless the screw driver head is in form of slot or PZZ.
- PMX Fuse holder is made of halogen free plastic, prepared for future restrictions on these substances.
- IEC (CB) tested.

	POLES	MODULES	REFERENCE		I _n (A)	U (V)	PACKING Uni./BOX
			WITHOUT INDICATOR	WITH INDICATOR			
8x32	1	1	485001	485008	25	400V AC/DC	12/180
	1 + N	2	485003	485009	25	400V AC/DC	6/90
	2	2	485004	485010	25	400V AC/DC	6/90
	3	3	485005	485011	25	400V AC/DC	4/60
	3 + N	4	485006	485012	25	400V AC/DC	3/45
	4	4	485007	485013	25	400V AC/DC	3/45



10x38	I	1	485101	485108	32	690VAC - 750VDC	12/180
	N	1	485102	-	32	690VAC - 750VDC	12/180
	1 + N	2	485103	485109	32	690VAC - 750VDC	6/90
	2	2	485104	485110	32	690VAC - 750VDC	6/90
	3	3	485105	485111	32	690VAC - 750VDC	4/60
	3 + N	4	485106	485112	32	690VAC - 750VDC	3/45
	4	4	485107	485113	32	690VAC - 750VDC	3/45



10x38 24VDC	1	1,5	-	485114	32	24DC	12
	2	3	-	485116	32	24DC	12

PMX MODULAR FUSE HOLDERS ACCESSORIES NEW

	REFERENCE	DESCRIPTION	PACKING
8x32	480005	PIN FOR MULTIPOLE ASSEMBLY	12
	485050	HANDLE TIES FOR MULTIPOLE ASSEMBLY	12
10x38	485051	LOCK ACCESSORY	5
	485052	SPECIAL IP20 PROTECTION ACCESSORY	24
	485053	PHASE SEPARATOR ACCESSORY	12
	485054	REPLACEMENT FUSING NEON INDICATOR 120/690V AC	6
	485055	REPLACEMENT FUSING LED INDICADOR 24V DC	6
	485656	SCREWS PROTECTION ACCESSORY	20



STANDARDS
IEC 60269-1 IEC 60269-2 EN 60269-1 EN 60269-2 IEC 60947-3 EN 60947-3

STANDARDS
CSA C22.2 4248-1 UL 4248-1

APPROVALS

TECHNICAL
TECHNICAL DATA PAGE 16

TECHNICAL
PMX FUSE HOLDERS MULTI-POLE ASSEMBLY PAGE 17

TECHNICAL
DIMENSIONS PAGE 17

TECHNICAL
PMX FUSE HOLDERS ASSEMBLY MICROSWITCH IDENTIFICATION BY LABEL LOCKING SYSTEM PAGE 19

COMPATIBLE
gG CYLINDRICAL FUSES PAGE 04

COMPATIBLE
aM CYLINDRICAL FUSES PAGE 06

COMPATIBLE
aR - aR HIGH SPEED FUSES FOR SEMICONDUCTORS SEE RAPIDPLUS

CYLINDRICAL FUSE HOLDERS

PMX MODULAR FUSE HOLDERS **NEW**

	POLES	MODULES	REFERENCE		I _n (A)	U (V)	PACKING Uni./BOX		
			WITHOUT INDICATOR	WITH INDICATOR					
14x51	I	1,5	485201	c US	485208	c US	50	690	6/90
	N	1,5	485202	c US	-	-	50	690	6/90
	I + N	3	485203	c US	485209	c US	50	690	3/45
	2	3	485204	c US	485210	c US	50	690	3/45
	3	4,5	485205	c US	485211	c US	50	690	2/30
	3 + N	6	485206	c US	485212	c US	50	690	1/18
	4	6	485207	c US	485213	c US	50	690	1/18
14x51 24VDC	1	1,5	-	-	485214	c US	50	24	6/90
	1+N	3	-	-	485215	c US	50	24	3/45
	2	3	-	-	485216	c US	50	24	3/45



PMX MODULAR FUSE HOLDERS WITH MICROSWITCH **NEW**

	POLES	MODULES	REFERENCE		I _n (A)	U (V)	PACKING Uni./BOX		
			PREBREAKING FUSING - PRESENCE	ONLY FUSION					
14x51	I	1,5	485220	c US	485226	c US	50	690	6/90
	I + N	3	485221	c US	485227	c US	50	690	3/45
	2	3	485222	c US	485228	c US	50	690	3/45
	3	4,5	485223	c US	485229	c US	50	690	2/30
	3+N	6	485224	c US	485230	c US	50	690	1/18
	4	6	485225	c US	485231	c US	50	690	1/18



PMX MODULAR FUSE HOLDERS ACCESSORIES **NEW**

14x51	REFERENCE	DESCRIPTION	PACKING
	480005	PIN FOR MULTIPOLE ASSEMBLY	12
	485356	HANDLE TIES FOR MULTIPOLE ASSEMBLY	12
	485357	HANDLE TIES FOR MICROSWITCH ASSEMBLY	12
	485258	LOCK SUPPORT	5
	485259	MICROSWITCH 1P *	5
	485260	MICROSWITCH 3P *	2
	485261	MICROSWITCH 3P (2M) *	2
	485262	MICROSWITCH UNIPOLAR EXTENSION	5
	485263	MICROSWITCH TRIPOLAR EXTENSION	2
	485264	REPLACEMENT FUSING INDICATOR NEON 120/690 VAC	3
	485265	REPLACEMENT FUSING INDICATOR LED 24 VDC	3
	485266	SPECIAL PROTECTION IP20 ACCESSORY PMX-14	12
		SPECIAL CONNECTION M6 ACCESSORY	12
	485656	SCREW PROTECTION ACCESSORY	12



* TO CONVERT STANDARD BASE ON MICROSWITCH BASE ONLY FUSING AND AS MICROSWITCH PMX SPARE PREBREAKING-FUSING-PRESENCE

STANDARDS
IEC 60269-1 IEC 60269-2 EN 60269-1 EN 60269-2 IEC 60947-3 EN 60947-3

STANDARDS
CSA C22.2 4248-1 UL 4248-1

APPROVALS

TECHNICAL
TECHNICAL DATA PAGE 19

TECHNICAL
PMX FUSE HOLDERS MULTI-POLE ASSEMBLY PAGE 20

TECHNICAL
DIMENSIONS PAGE 21

TECHNICAL
PMX FUSE HOLDERS ASSEMBLY MICROSWITCH IDENTIFICATION BY LABEL LOCKING SYSTEM PAGE 22

COMPATIBLE
gG CYLINDRICAL FUSES PAGE 04

COMPATIBLE
aM CYLINDRICAL FUSES PAGE 06

COMPATIBLE
aR - aR HIGH SPEED FUSES FOR SEMICONDUCTORS SEE RAPIDPLUS

CYLINDRICAL FUSE HOLDERS

PMX MODULAR FUSE HOLDERS

	POLES	MODULES	REFERENCE		I _n (A)	U (V)	PACKING Uni./BOX		
			WITHOUT INDICATOR	WITH INDICATOR					
22x58	1	2	485301		485308		100*	690	6/48
	N	2	485302		-	-	100*	690	6/48
	1+N	4	485303		485309		100*	690	3/24
	2	4	485304		485310		100*	690	3/24
	3	6	485305		485311		100*	690	2/16
	3+N	8	485306		485312		100*	690	1/8
	4	8	485307		485313		100*	690	1/8
22x58 24VDC	1	2	-	-	485314		100*	24	6/48
	1+N	4	-	-	485315		100*	24	3/24
	2	4	-	-	485316		100*	24	3/24

* ACCEPT 125A FUSE-LINKS



PMX MODULAR FUSE HOLDERS WITH MICROSWITCH

	POLES	MODULES	REFERENCE		I _n (A)	U (V)	PACKING Uni./BOX		
			PREBREAKING FUSING - PRESENCE	ONLY FUSION					
22x58	1	2	485320		485326		100*	690	6/48
	1+N	4	485321		485327		100*	690	3/24
	2	4	485322		485328		100*	690	3/24
	3	6	485323		485329		100*	690	2/16
	3+N	8	485324		485330		100*	690	1/8
	4	8	485325		485331		100*	690	1/8

* ACCEPT 125A FUSE-LINKS



PMX MODULAR FUSE HOLDERS ACCESSORIES

22x58	REFERENCE	DESCRIPTION	PACKING
	480005	PIN FOR MULTIPOLE ASSEMBLY	12
	485356	HANDLE TIES FOR MULTIPOLE ASSEMBLY	12
	485357	HANDLE TIES FOR MICROSWITCH ASSEMBLY	12
	485358	LOCK SUPPORT	5
	485359	MICROSWITCH 1P *	5
	485360	MICROSWITCH 3P *	2
	485361	MICROSWITCH 3P (2M) *	2
	485362	MICROSWITCH UNIPOLAR EXTENSION	5
	485363	MICROSWITCH TRIPOLAR EXTENSION	2
	485364	REPLACEMENT FUSING INDICATOR NEON 120/690 VAC	3
	485365	REPLACEMENT FUSING INDICATOR LED 24 VDC	3
	485366	SPECIAL PROTECTION IP20 ACCESSORIE PMX-22	12
	485367	SPECIAL CONNECTION M8 ACCESSORY	12

* TO CONVERT STANDARD BASE ON MICROSWITCH BASE ONLY FUSING AND AS MICROSWITCH PMX SPARE PREBREAKING- FUSING-PRESENCE

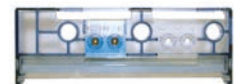

STANDARDS
IEC 60269-1 IEC 60269-2 EN 60269-1 EN 60269-2 IEC 60947-3 EN 60947-3

STANDARDS
CSA C22.2 4248-1 UL 4248-1

APPROVALS

TECHNICAL
TECHNICAL DATA PAGE 16

TECHNICAL
PMX FUSE HOLDERS MULTI-POLE ASSEMBLY PAGE 17

TECHNICAL
DIMENSIONS PAGE 17

TECHNICAL
PMX FUSE HOLDERS ASSEMBLY MICROSWITCH IDENTIFICATION BY LABEL LOCKING SYSTEM PAGE 22

COMPATIBLE
gg CYLINDRICAL FUSES PAGE 04

COMPATIBLE
aM CYLINDRICAL FUSES PAGE 06

COMPATIBLE
aR - aR HIGH SPEED FUSES FOR SEMICONDUCTORS SEE RAPIDPLUS

CYLINDRICAL FUSE HOLDERS

PMC COMPACT FUSE HOLDERS

NEW

Compact fuse holders for industrial cylindrical fuse links. Very low dimensions. For mounting on DIN/EN rail. Single phase models or single phase + neutral in only one module. Multi-pole units can be made with connection accessories. PMC fuse holders are made with self-extinguishable materials and have silver plated copper contacts.

	POLES	MODULES 17,5 mm	REFERENCE	I _n (A)	U (V)	PACKING Uni./BOX
8x32	I	1	483500	25	400	12/336
	N	1	483502	32	400	12/336
	I + N	1	483504	25	400	12/336
	I + N	2	483506	25	400	6/168
	2	2	483508	25	400	6/168
	3	3	483510	25	400	4/112
	3 + N	3	483512	25	400	4/112
	3 + N	4	483514	25	400	3/84
	4	4	483516	25	400	3/84
10x38	I	1	483530	32	500	12/336
	N	1	483502	32	500	12/336
	I + N	1	483534	32	500	12/336
	I + N	2	483536	32	500	6/168
	2	2	483538	32	500	6/168
	3	3	483540	32	500	4/112
	3 + N	3	483542	32	500	4/112
	3 + N	4	483544	32	500	3/84
	4	4	483546	32	500	3/84



483530

PMC COMPACT FUSE HOLDERS ACCESSORIES

8x32 10x38	SIZE	REFERENCE	DESCRIPTION	PACKING
	8x32 / 10x38	480005	PINS FOR MULTIPOLE ASSEMBLY	12/300
	8x32 / 10x38	483550	PMC HANDLE TIES FOR MULTIPOLE ASSEMBLY	12/300
	8x32 / 10x38	483552	PMC MULTIPOLE ASSEMBLY KIT	12/300

PMX CC MODULAR FUSE HOLDERS

NEW

Modular fuse holders for cylindrical CC class fuse links. For mounting on DIN/EN rail. Single phase and multi-pole types. Available with fusing indicator. Multi-pole units can be made with connection accessories. PMCC fuse holders are made with self-extinguishable materials and have silver plated copper contacts. UL approval.

POLES	REFERENCE		I _n (A)	U (V)	PACKING Uni./BOX
	WITHOUT INDICATOR	WITH INDICATOR			
I	485181	485188	30	600	12/180
II	485184	485190	30	600	6/90
III	485185	485191	30	600	4/60



485181

STANDARDS	STANDARDS	APPROVALS
IEC 60269-1 IEC 60269-2 EN 60269-1 EN 60269-2 IEC 60947-3 EN 60947-3	CSA C22.2 4248-1 UL 4248-1 UL 4248-4	

TECHNICAL	TECHNICAL	TECHNICAL
TECHNICAL DATA	PMC & PMCC FUSE HOLDERS MULTI-POLE ASSEMBLY	PMC FUSE HOLDER DIMENSIONS
PAGE 16	PAGE 17	PAGE 22

COMPATIBLE	COMPATIBLE	COMPATIBLE
gG CYLINDRICAL FUSES	aM CYLINDRICAL FUSES	aR - aR HIGH SPEED FUSES FOR SEMICONDUCTORS
PAGE 04	PAGE 06	SEE RAPIDPLUS

CYLINDRICAL FUSE HOLDERS

PMF MODULAR FUSE HOLDERS WITH INTEGRATED NEUTRAL

Modular fuse holders for industrial cylindrical fuse links. For mounting on DIN/EN rail. Single phase models, single-phase+neutral in only one module and multi-pole types. Available with fusing indicator or with microswitch for use with fuse links with striker (only fusing detection or fusing+pre-breaking+fuse link detection). Multi-pole units can be made of connection accessories. PMF fuse holders are made of self-extinguishable materials and have silver plated copper contacts.

10x38

POLES	MODULES 17,5 mm	REFERENCE		I _n (A)	U (V)	PACKING Uni./BOX
		WITHOUT INDICATOR	WITH INDICATOR			
I	1	480032	–	32	690	12/192
N	1	480032 N	–	32	690	12/192
I + N	1	480135	480335 I	32	400	12/192
I + N	2	480132	–	32	690	6/96
2	2	480232	–	32	690	6/96
3	3	480332	–	32	690	4/64
3 + N	3	480335	–	32	400	4/64
3 + N	4	480432	–	32	690	3/48
4	4	480532	–	32	690	3/48



480135I

PMF MODULAR FUSE HOLDERS ACCESSORIES

8x32
10x38

REFERENCE	DESCRIPTION	PACKING
480005	PINS FOR MULTIPOLE ASSEMBLY	12
480006	HANDLE TIES FOR MULTIPOLE ASSEMBLY	12



480005



480006

STANDARDS	APPROVALS
IEC 60269-1 IEC 60269-2 EN 60269-1 EN 60269-2 IEC 60947-3 EN 60947-3	

TECHNICAL	TECHNICAL	TECHNICAL
TECHNICAL DATA	PMF FUSE HOLDERS MULTI-POLE ASSEMBLY	DIMENSIONS
PAGE 16	PAGE 17	PAGE 22

COMPATIBLE	COMPATIBLE	COMPATIBLE
gG CYLINDRICAL FUSES	aM CYLINDRICAL FUSES	aR - gR HIGH SPEED FUSES FOR SEMICONDUCTORS
PAGE 04	PAGE 06	SEE RAPIDPLUS

CYLINDRICAL FUSE HOLDERS

BAC OPEN FUSE BASES

Open bases for cylindrical fuses. The bases BAC for cylindrical fuses are particularly suitable for semiconductor fuses with high power dissipation and therefore needed to be mounted on open bases to facilitate the heat dissipation. Fixation on panel by screw. Made of thermosetting self extinguishing material.

	REFERENCE	I_n (A)	U (V)	PACKING Uni./BOX
10x38	451210	32	690	20/300
14x51	451220	50	690	10/240
22x58	451230	100	690	10/120



451230

PMB PLUG CONNECTION FUSE HOLDERS **NEW**

	REFERENCE	I_n (A)	U (V)	PACKING Uni./BOX
10x38	490030	32	500	20/100



CLIP CONTACT FOR Ø10 FUSE-LINKS **NEW**

Clip contact for Ø10 cylindrical fuse links. Screw fixation and PCB versions. Manufactured in tinned bronze. All the materials are according to the European Directive 2002/95/EC RoHS (Restriction of the use of certain hazardous substances in electrical material).

	REFERENCE	DESCRIPTION	I_n (A)	P_d max (W)	PACKING Uni./BOX
10x38 10x85	482001	Ø10 CLIP CONTACT SCREW FIXATION	25	4	50/200
	482002	Ø10 CLIP CONTACT FOR PCB	25	4	50/200



482001



482002

STANDARDS	APPROVALS
IEC 60269-1 IEC 60269-2 EN 60269-1 EN 60269-2	

TECHNICAL	TECHNICAL
TECHNICAL DATA	DIMENSIONS
PAGE 16	PAGE 23

COMPATIBLE
gG CYLINDRICAL FUSES
PAGE 04

COMPATIBLE
aM CYLINDRICAL FUSES
PAGE 06

COMPATIBLE
aR - gR HIGH SPEED FUSES FOR SEMICONDUCTORS
SEE RAPIDPLUS

TECHNICAL
gG CYLINDRICAL FUSES
 t-I CHARACTERISTICS

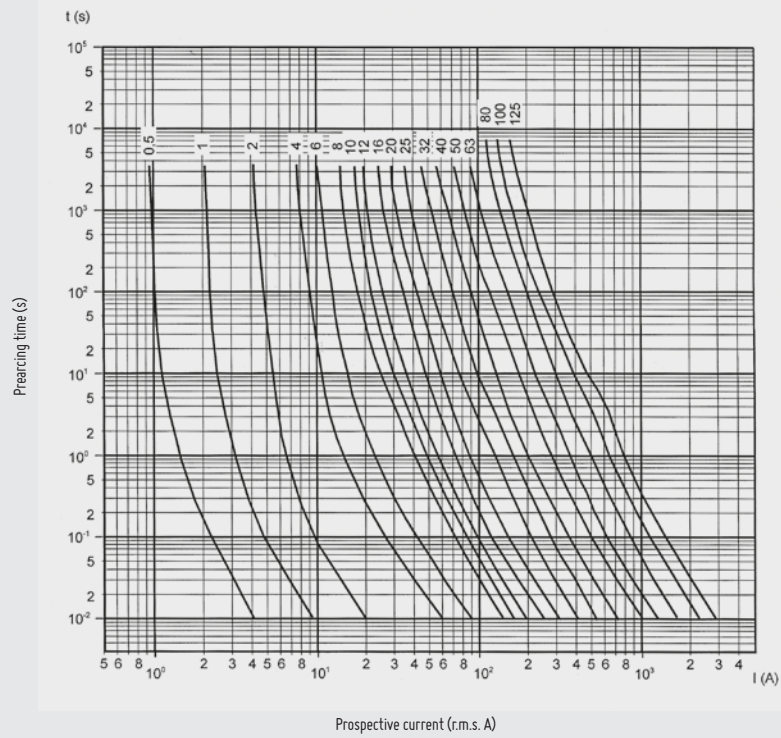

TECHNICAL
gG CYLINDRICAL FUSES
 CUT-OFF CHARACTERISTICS

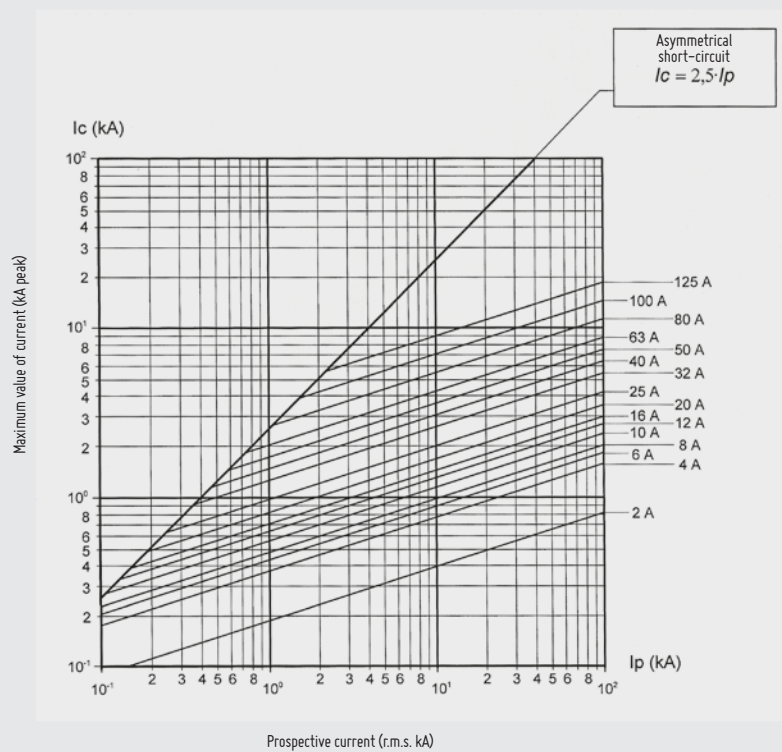

TECHNICAL

gG CYLINDRICAL FUSES I²t CHARACTERISTICS

I _n (A)	I ² t Prearcing (A ² s)	I ² t 400 V (A ² s)	I ² t 500 V (A ² s)	I ² t 690 V (A ² s)
0,5	4,0	8,6	10,4	15,0
1	6,5	13,2	15,7	22,0
2	7,0	14,6	17,6	25,0
4	45	90	108	150
6	70	140	166	230
8	80	158	188	260
10	120	248	297	420
12	180	362	431	600
16	270	536	636	880
20	500	981	1.162	1.600
25	800	1.688	2.034	2.900
32	1.200	2.412	2.871	4.000
40	2.500	4.907	5.808	8.000
50	5.100	11.262	13.728	20.000
63	7.900	16.451	19.762	28.000
80	16.000	37.242	46.000	–
100	28.000	68.072	85.000	–
125	40.000	120.000	–	–

TECHNICAL

gG CYLINDRICAL FUSES POWER DISSIPATION

I _n (A)	SIZE			
	8,5x32 (VW)	10x38 (VW)	14x51 (VW)	22x58 (VW)
0,5	1,2	1,43	–	–
1	2,0	2,77	3,90	–
2	0,5	0,60	0,90	1,00
4	0,8	0,70	1,00	1,10
6	1,1	0,85	1,15	1,30
8	1,3	0,75	1,00	1,10
10	1,0	1,00	1,30	1,50
12	1,2	1,30	1,70	1,80
16	1,5	1,60	2,00	2,10
20	2,0	2,00	2,50	2,70
25	–	2,60	3,30	3,30
32	–	2,90	3,50	3,50
40	–	–	4,75	4,00
50	–	–	4,80	5,50
63	–	–	–	6,90
80	–	–	–	7,80
100	–	–	–	9,00
125	–	–	–	11,4

TECHNICAL
aM CYLINDRICAL FUSES
t-I CHARACTERISTICS

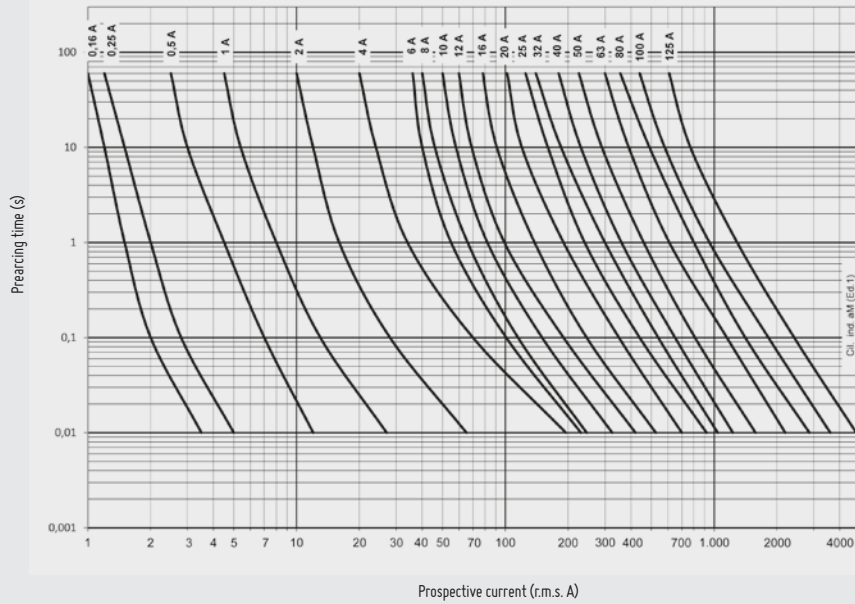

TECHNICAL
aM CYLINDRICAL FUSES
CUT-OFF CHARACTERISTICS

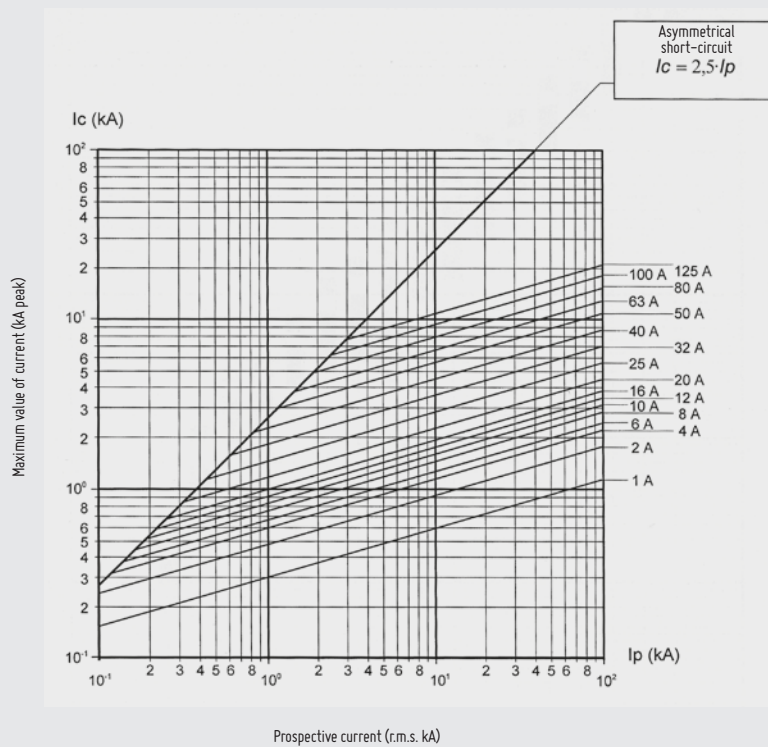

TECHNICAL
aM CYLINDRICAL FUSES
I²t CHARACTERISTICS

I _n (A)	I _{tt} I _{pre-arcing} (A ² s)	I ² t 400 V (A ² s)	I ² t 500 V (A ² s)	I ² t 690 V (A ² s)
0,16	3,0	6,7	8,2	12,0
0,25	4,0	8,6	10,4	15,0
0,5	6,5	13,2	15,7	22,0
1	9,5	18,5	21,9	30,0
2	40	83	99	140
4	90	181	215	300
6	120	250	300	425
8	220	448	535	750
10	300	733	916	1.400
12	380	936	1.173	1.800
16	550	1.608	2.103	3.500
20	950	2.488	3.165	5.000
25	1.300	3.728	4.851	8.000
32	2.500	6.207	7.791	12.000
40	4.500	10.685	13.263	20.000
45	8.000	16.538	19.831	28.000
50	10.000	19.626	23.230	32.000
63	15.000	31.520	37.950	54.000
80	30.000	59.088	70.000	–
100	50.000	113.945	140.000	–
125	80.000	200.000	–	–

TECHNICAL
aM CYLINDRICAL FUSES
POWER DISSIPATION

I _n (A)	SIZE			
	8,5x32 (VW)	10x38 (VW)	14x51 (VW)	22x58 (VW)
0,16	–	0,24	–	–
0,25	–	0,36	0,41	–
0,5	–	0,49	0,69	–
1	0,10	0,10	0,14	–
2	0,16	0,18	0,24	0,29
4	0,25	0,31	0,45	0,48
6	0,35	0,32	0,42	0,47
8	0,40	0,52	0,70	0,73
10	0,65	0,55	0,53	0,74
12	–	0,63	0,88	0,83
16	–	0,92	1,16	1,21
20	–	0,96	1,23	1,29
25	–	1,40	1,46	1,53
32	–	–	2,04	2,13
40	–	–	2,60	3,40
45	–	–	2,85	–
50	–	–	2,90	3,48
63	–	–	–	4,46
80	–	–	–	5,86
100	–	–	–	6,61
125	–	–	–	8,42

CYLINDRICAL MODULAR FUSE HOLDERS

	PMF 8x32	PMF 10x38	PMX 8x32	PMX 10x38	PMX 14x51	PMX 22x58	PMX CC	PMC 8x32	PMC 10x38	BAC 10x38	BAC 14x51	BAC 22x58
RATED CURRENT	25 A	32 A	25 A	32 A	50 A	100 A	30 A	25 A	32 A	32 A	50 A	100 A
RATED VOLTAGE	400 V	690 V	400 V	690 V AC 750 V DC	690 V	690 V	600 V	400 V	690 V	690 V	690 V	690 V
RATED POWER DISSIPATION	2.5 W	3 W	2.5 W	3 W	5 W	9.5 W	3 W	3 W	3 W	8 W	12 W	20 W
UTILIZATION CATEGORY	AC-228 400V	AC-228 500V AC-218 690 V	AC-228 400 V	AC-228 500 V AC-218 690 V DC-208 750 V DC	AC-228 500 V AC-218 690 V	AC-218 690 V	—	AC-20	AC-20			
PROTECTION DEGREE	IP-20	IP-20	IP-20	IP-20	IP-20	IP-20	IP-20	IP-20	IP-20	IP-00	IP-00	IP-00
OPERATING TEMPERATURE	-20 ... 70 °C	-20 ... 70 °C	-20 ... 70 °C	-20 ... 70 °C	-20 ... 70 °C	-20 ... 70 °C	-20 ... 70 °C	-20 ... 70 °C	-20 ... 70 °C	-20 ... 60 °C	-20 ... 60 °C	-20 ... 60 °C
STORAGE TEMPERATURE	-40 ... 80 °C	-40 ... 80 °C	-40 ... 80 °C	-40 ... 80 °C	-40 ... 80 °C	-40 ... 80 °C	-40 ... 80 °C	-40 ... 80 °C	-40 ... 80 °C	-40 ... 80 °C	-40 ... 80 °C	-40 ... 80 °C
DERATING TEMPERATURE	20 °C	1	1	1	1	1	1	1	1	1	1	1
	0.95	0.95	0.95	0.95	0.95	0.95	0.95	0.95	0.95	0.95	0.95	0.95
	0.9	0.9	0.9	0.9	0.9	0.9	0.9	0.9	0.9	0.9	0.9	0.9
	0.8	0.8	0.8	0.8	0.8	0.8	0.8	0.8	0.8	0.8	0.8	0.8
	1 ... 4	1	1	1	1	1	1	1	1	1	1	1
	0.8	0.8	0.8	0.8	0.8	0.8	0.8	0.8	0.8	0.8	0.8	0.8
	0.7	0.7	0.7	0.7	0.7	0.7	0.7	0.7	0.7	0.7	0.7	0.7
	≥ 10	0.6	0.6	0.6	0.6	0.6	0.6	0.6	0.6	0.6	0.6	0.6
FIXING	RAIL DIN / EN	•	•	•	•	•	•	•	•	•	•	•
	SCREW	—	—	—	—	—	—	—	—	—	—	—
CONNECTING WIRE	0.75 ... 1.6 mm ² STRANDED 0.75 ... 2.5 mm ² SOLID	0.75 ... 1.6 mm ² STRANDED 0.75 ... 2.5 mm ² SOLID	0.75 ... 1.6 mm ² STRANDED 0.75 ... 1.6 mm ² SOLID	0.75 ... 1.6 mm ² STRANDED 0.75 ... 1.6 mm ² SOLID	1.5 ... 2.5 mm ² STRANDED 1.5 ... 3.5 mm ² SOLID	1.5 ... 3.5 mm ² STRANDED 1.5 ... 5.0 mm ² SOLID	0.75 ... 1.6 mm ² STRANDED 0.75 ... 1.6 mm ² SOLID	0.75 ... 6 mm ² STRANDED 0.75 ... 10 mm ² SOLID	0.75 ... 6 mm ² STRANDED 0.75 ... 10 mm ² SOLID	Ø 4 mm TERMINAL	2.5 ... 3.5 mm ² STRANDED 4 ... 3.5 mm ² SOLID	4 ... 70 mm ² STRANDED 6 ... 9.5 mm ² SOLID
WITH LIGHTNING INDICATOR	120 ... 400V AC 2.5 Nm (IP+N 1M) 12 ... 24V DC	120 ... 690V AC 2.5 Nm (IP+N 1M) 12 ... 24V DC	120 ... 400V AC 2.5 Nm	120 ... 690V AC 2.5 Nm	230 ... 690V AC 3 Nm 24 ... 60 VDC	230 ... 690V AC 4 Nm 24 ... 60 VDC	120 ... 690V AC 2.5 Nm	—	—	—	2.5 Nm	3.5 Nm
MAX. TIGHTENING TORQUE	2.5 Nm (IP+N 1M)	2.5 Nm (IP+N 1M)	2.5 Nm	2.5 Nm	3 Nm	4 Nm	2.5 Nm	2 Nm	2 Nm	2.5 Nm	2.5 Nm	3.5 Nm
WITH MICROSWITCH 5A-250V	—	—	—	—	•	•	•	—	—	—	—	—
MULTIPOLAR UNION WITH ACCESSORIES	•	•	•	•	•	•	•	•	•	•	•	•
LABEL HOLDER	—	—	•	•	•	•	•	•	•	•	•	•
LOCKING ACCESSORIES	—	—	•	•	•	•	•	•	•	•	•	•



CYLINDRICAL FUSE HOLDERS

TECHNICAL
PMF MODULAR FUSE HOLDERS
 MULTI-POLE ASSEMBLY

PMX

PMC

NEW

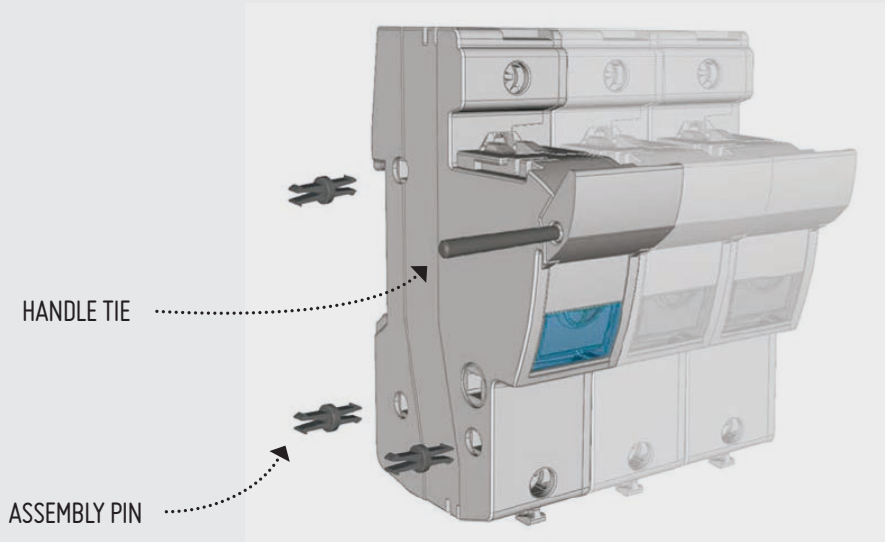

TECHNICAL
PMX MODULAR FUSE HOLDERS
 DIMENSIONS

8x32
 10x38
 CC^{CLASS}

NEW

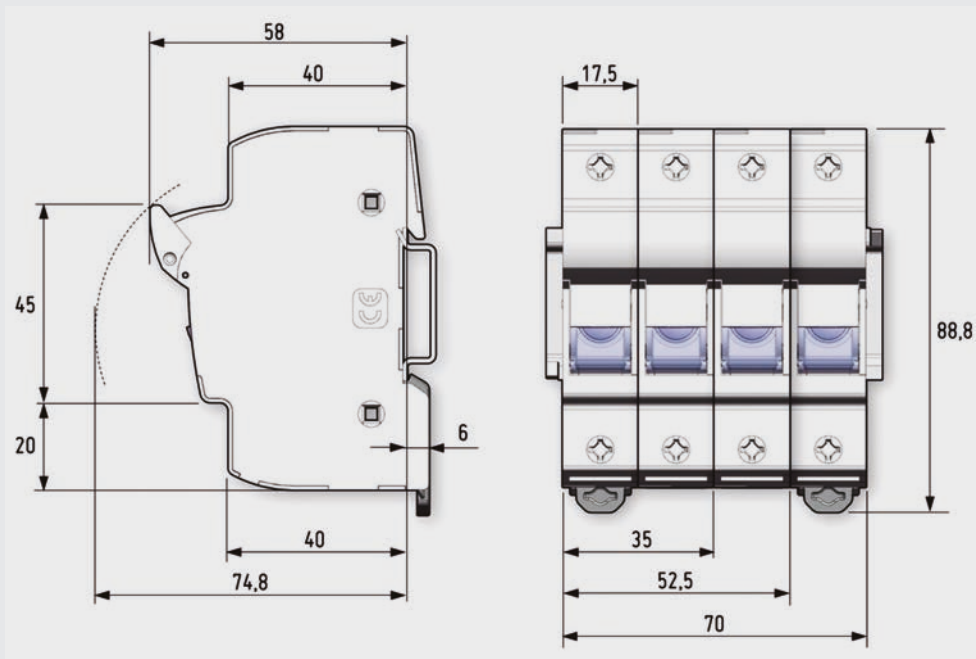

CYLINDRICAL FUSE HOLDERS

TECHNICAL
PMX MODULAR FUSE HOLDERS
DIMENSIONS

14x51

NEW

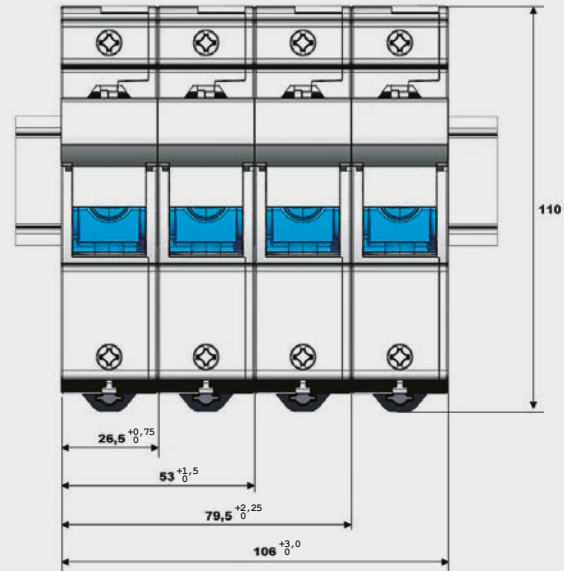
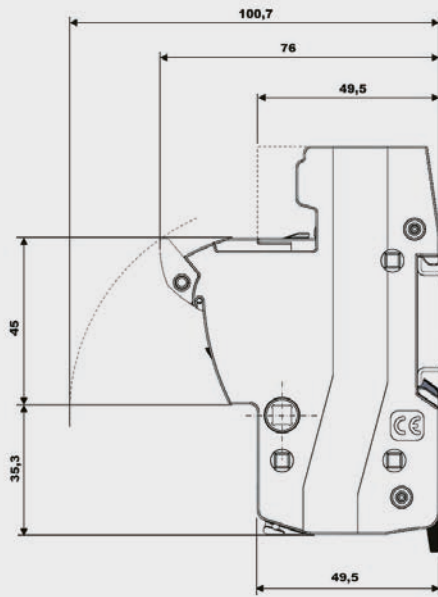

TECHNICAL
PMX MODULAR FUSE HOLDERS
DIMENSIONS

22x58

NEW

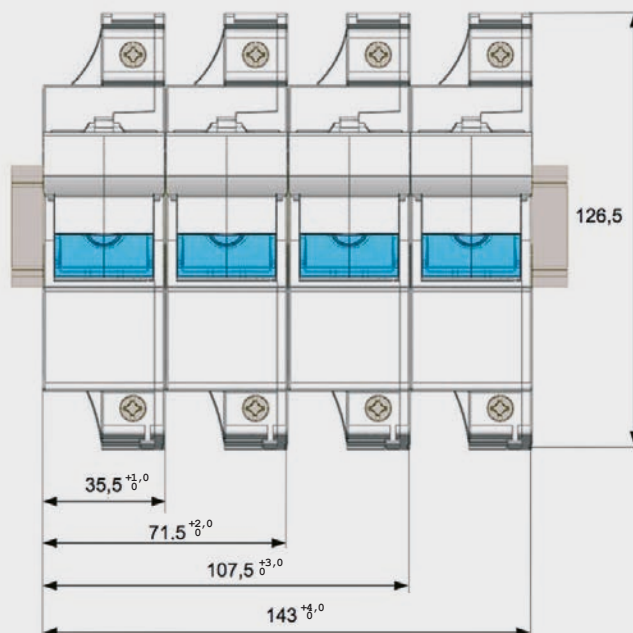
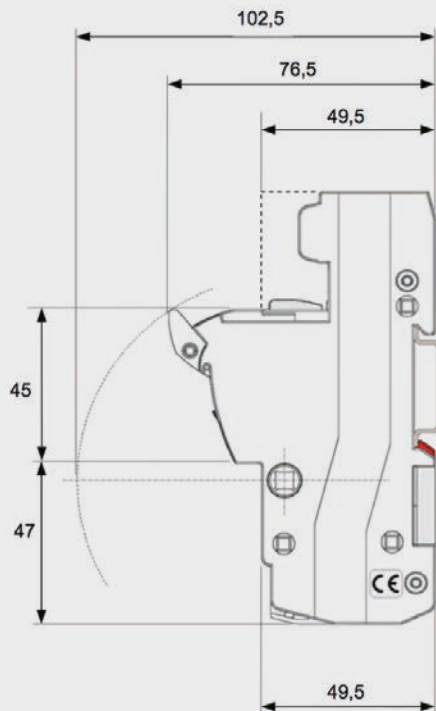

CYLINDRICAL FUSE HOLDERS

TECHNICAL

PMX MODULAR FUSE HOLDERS MICROSWITCH MOUNTING

14x51
22x58

Put on the **microswitch** on the guides, and push in horizontal movement to the final position.

* For **ONLY FUSION** accessory, first mount the lifter in his place.

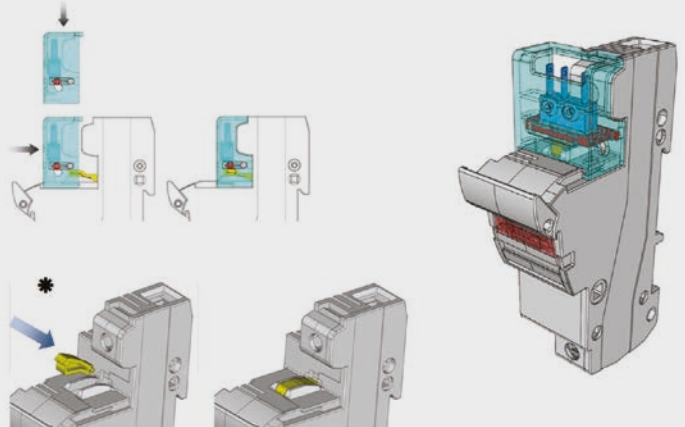
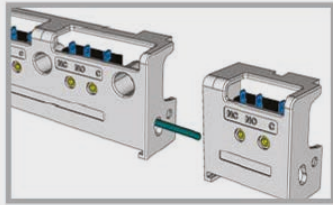

NEW

TECHNICAL

PMX MODULAR FUSE HOLDERS IDENTIFICATION BY LABEL

8x32
10x38
CC^{CLASS}
14x51
22x58

Open the **label-holder part** when the fuse holder is totally closed or totally open, put on the label and close.

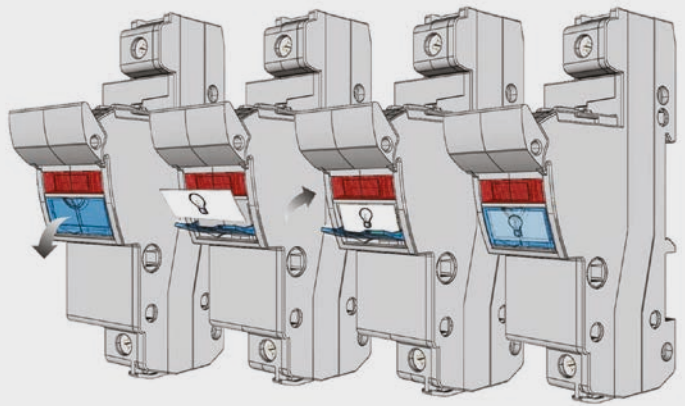

NEW

TECHNICAL

PMX MODULAR FUSE HOLDERS PADLOCK ACCESSORY

8x32
10x38
CC^{CLASS}
14x51
22x58

To avoid the operation and connection when the fuseholder is open, introduce the padlock accessory into the symmetrical holes.

All accessories allow using three padlocks at the same time and have a repose mode.

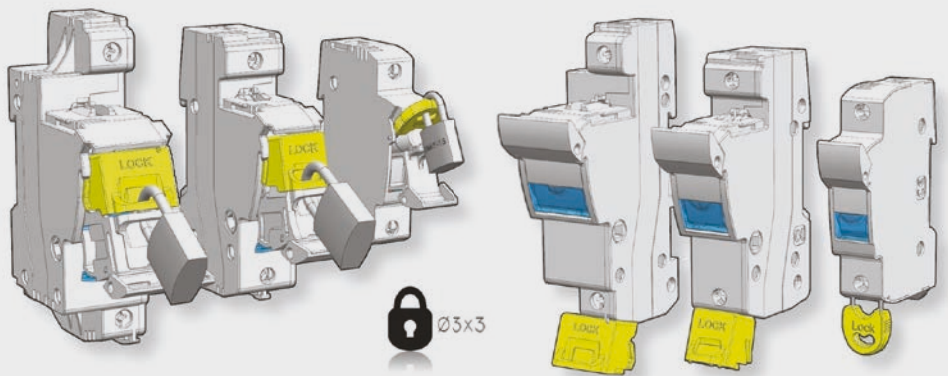

Ø3x3

NEW

CYLINDRICAL FUSE HOLDERS

TECHNICAL

PMX MODULAR FUSE HOLDERS SPECIAL IP20 PROTECTION

8x32
10x38
CC^{CLASS}
14x51
22x58

The accessory must be positioned in the wire entries, if it's necessary to achieve the IP20 degree of protection with thin wires.

SIZE	SECTION FLEXIBLE WIRE (mm ²)	SECTION SOLID WIRE (mm ²)	LENGTH (mm)
8x32	≤6	≤10	10
10x38	≤6	≤10	10
14x51	≤10	≤16	14
22x58	≤16	≤25	18

NEW

MANUAL ASSEMBLY

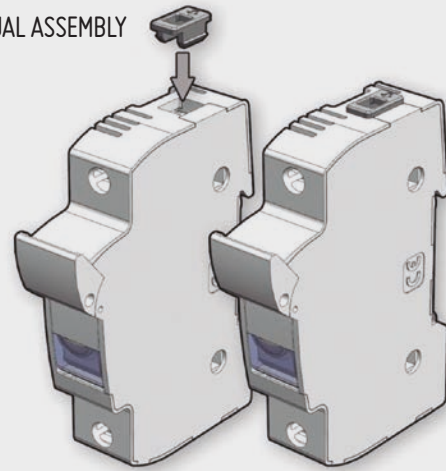

TECHNICAL

PMX MODULAR FUSE HOLDERS PHASE SEPARATORS ACCESSORY

8x32
10x38
CC^{CLASS}

The accessory increases the distance between phases in multipolar assemblies.

NEW

MANUAL ASSEMBLY

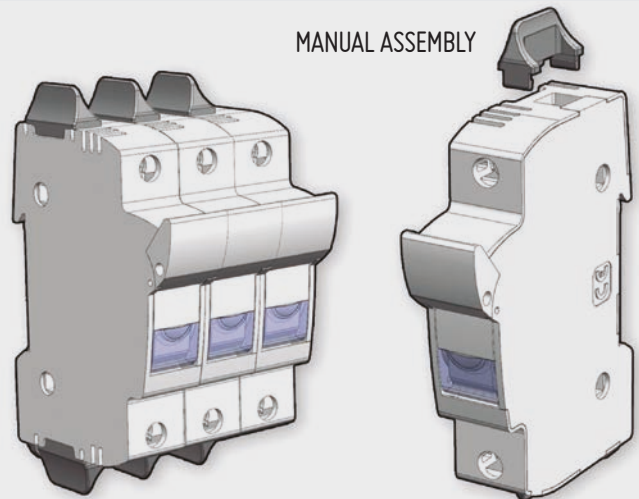

TECHNICAL

PMX MODULAR FUSE HOLDERS SCREW PROTECTION ACCESSORY

8x32
10x38
CC^{CLASS}
14x51

Protection accessory to avoid the screws manipulation and improve the protection degree.

NEW

MANUAL ASSEMBLY

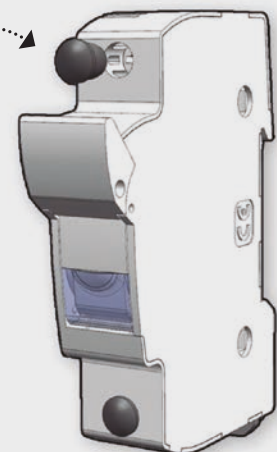

CYLINDRICAL FUSE HOLDERS

TECHNICAL

PMX MODULAR FUSE HOLDERS SCREW FIXATION ACCESSORY

8x32
10x38 First mount the accessory with screws, then mount the fuseholder (there are available different accessories depending the number of the fuseholder).

REFERENCE DESCRIPTION

485650	25MM SCREW FIXATION ACCESSORY
485651	50MM SCREW FIXATION ACCESSORY
485652	75MM SCREW FIXATION ACCESSORY
485653	100MM SCREW FIXATION ACCESSORY
485654	125MM SCREW FIXATION ACCESSORY
485655	175MM SCREW FIXATION ACCESSORY

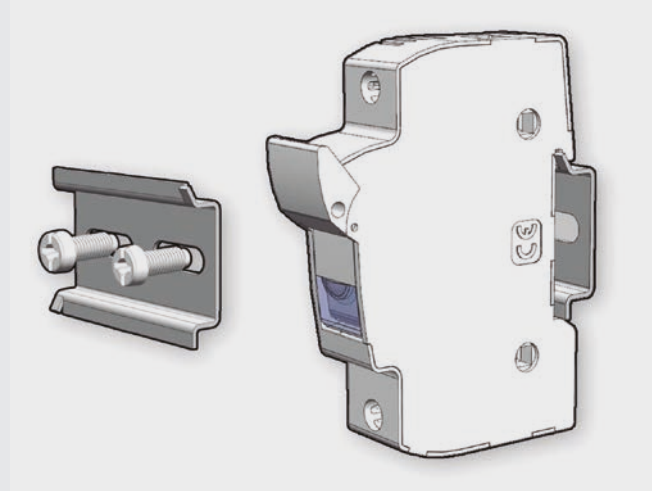

NEW

TECHNICAL

PMX MODULAR FUSE HOLDERS SPECIAL ACCESSORY FOR SCREW CONNECTION

14x51
22x58

SIZE	REFERENCE	A	B (mm)	C (mm)	D (mm)
14x51	485271	M6	14,5	25	128,5
22x58	485367	M8	15	23,5	154,5

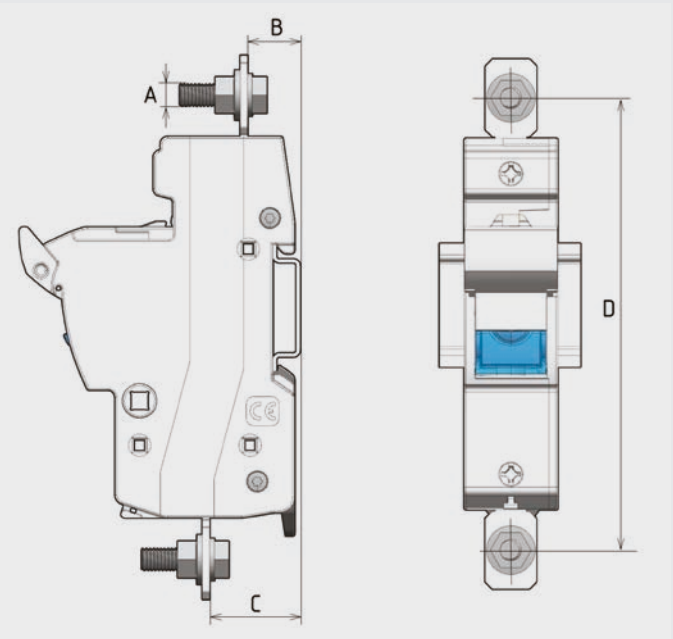

NEW

CYLINDRICAL FUSE HOLDERS

TECHNICAL
PMF MODULAR FUSE HOLDERS
 DIMENSIONS

PMCC

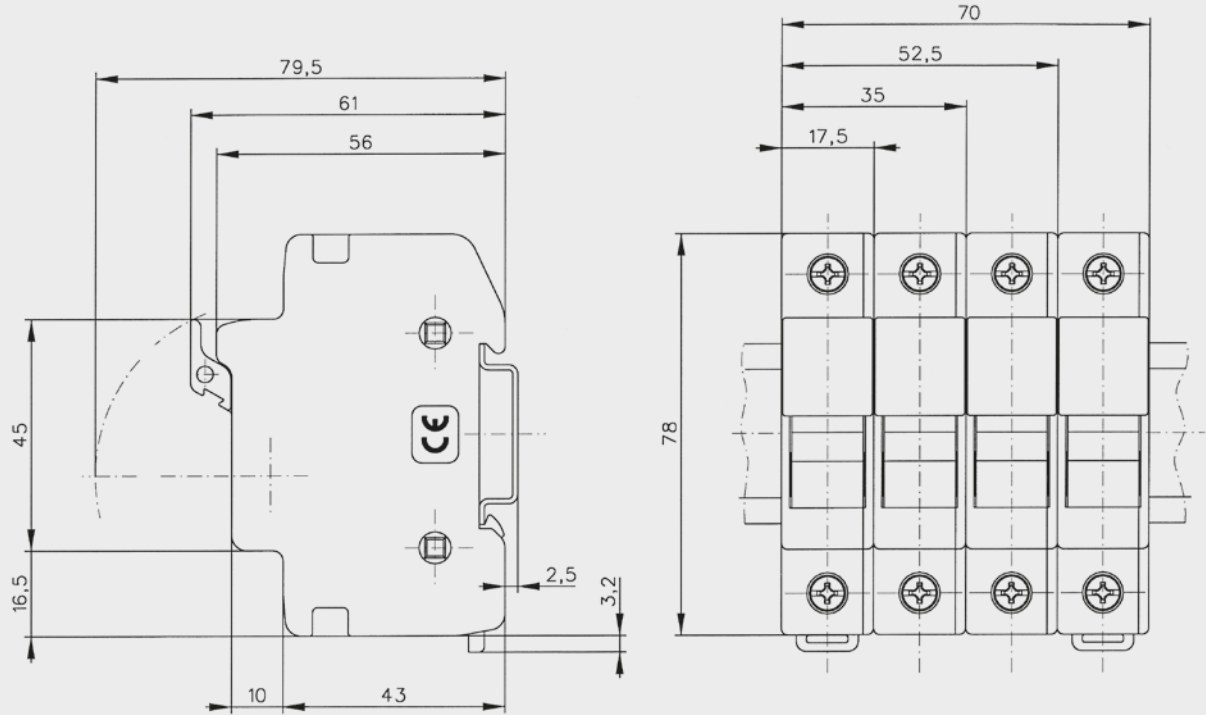

TECHNICAL
PMC COMPACT FUSE HOLDERS
 DIMENSIONS

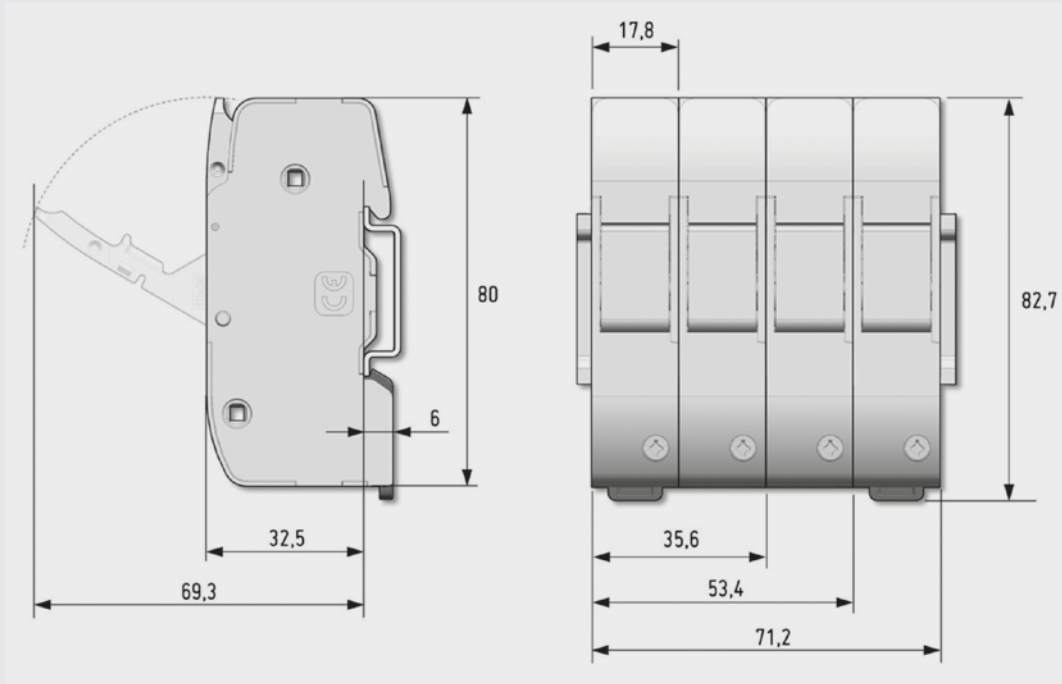

CYLINDRICAL FUSE HOLDERS

TECHNICAL

BAC OPEN FUSE HOLDERS DIMENSIONS

NEW

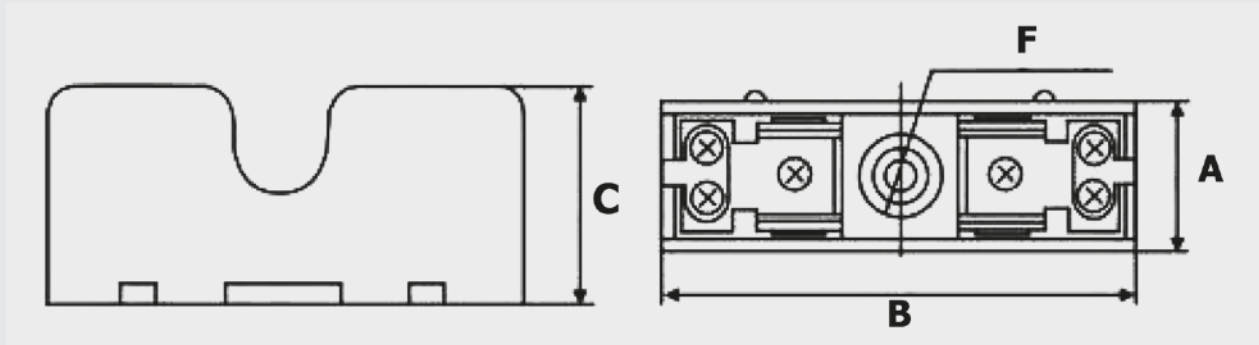

SIZE	A	B	C	ØF
10x38	24	81	35	4
14x51	30	91	37	5
22x58	37	108	48	6

TECHNICAL

CLIP CONTACT FOR Ø10 FUSE-LINKS DIMENSIONS

NEW

10x38
10x85

INSTALLATION INSTRUCTIONS

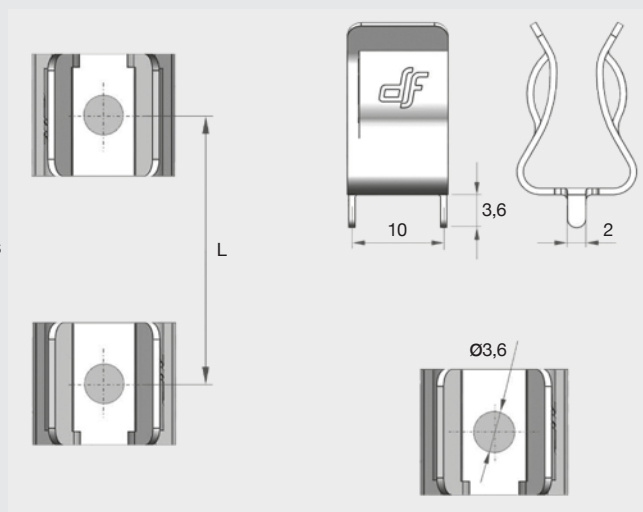

Ø10 CLIP CONTACT FOR PCB

SIZE	L
10x38	42
10x85	89,6

Ø10 CLIP CONTACT SCREW

SIZE	L
10x38	32
10x85	79,6

TECHNICAL

gG CYLINDRICAL FUSES DC APPLICATIONS

Fuses are generally suitable for both AC and DC applications. The DC performance of fuse-links is different and AC ratings cannot be used for DC applications. There is no simple rule that safely converts an AC voltage rating of a fuse-link to DC voltage rating. For this reason it is necessary to take into account a lot of aspects in order to determine the DC applications.

In the **DF ELECTRIC gG cylindrical fuses** it is necessary to take into account the following considerations:

- The power dissipations are the same in AC (RMS value) and the DC values.
- The time current characteristics are the same for DC applications under steady-state conditions.
- The DC rated voltage and maximum breaking capacity are lower than the AC values (see the table).

SIZE	RATED CURRENT	MAX. DC VOLTAGE	DC BREAKING CAPACITY
8,5x31,5	0,5A...10A 12A...20A	150V DC 60V DC	5 kA
10x38	0,5A...16A 20A...32A	250V DC 80V DC	15 kA
14x51	1A...25A 32A & 40A 50A	440V DC 80V DC 48V DC	15 kA
22x58	2A...63A 80A & 100A 125A	440V DC 80V DC 48V DC	15 kA

NOTES

These values are referred to a time constant L/R = 15 ms.

For higher values of time constant, the maximum utilization voltage must be reduced.

For circuits with very inductive behaviour, we recommend to connect two fuses in series.

THE PROTECTION FORMULA

BY  **Electric**

ELECTRONIC



CYLINDRICAL



PHOTOVOLTAIC



RAPIDPLUS



NH



SPECIAL FUSES



DOMESTIC



D & DO



TRANSFORMERS





HEAD OFFICE & FACTORY

SILICI, 67-69
08940 CORNELLA DE LLOBREGAT
BARCELONA
SPAIN
Tel. +34 93 377 85 85
Fax +34 93 377 82 82

EXPORT SALES

Tel. +34 93 475 08 64
Fax +34 93 480 07 75
export@df-sa.es

NATIONAL SALES

Tel. 93 475 08 64
Fax 93 480 07 76
comercial@df-sa.es

www.df-sa.es



PROTECTING THE WORLD

